



a landscapeforms® company

Square Series LANDSCAPE PLANTERS

Four-sided landscape planter with tapered radius sides.



TO SPECIFY

Select the SS product number along with the options below.

Drainage

- Standard diameter hole: approximately 2-3/8"
- (3) drainage holes for SS-18 model
- (2) drainage holes for SS-15 model
- Custom size to function with irrigation & drainage (note size of plumbing fixture to be used)

Concrete Color

- Natural gray concrete
- 9 standard color options available
- Additional color mixing available

Finishing

- Bituminous sealer (suggested for interior applications)
- Sandblast finish

Notes

- See website to download CSI specifications
- Prices vary based on color, sandblasting, sealer and extra drain holes

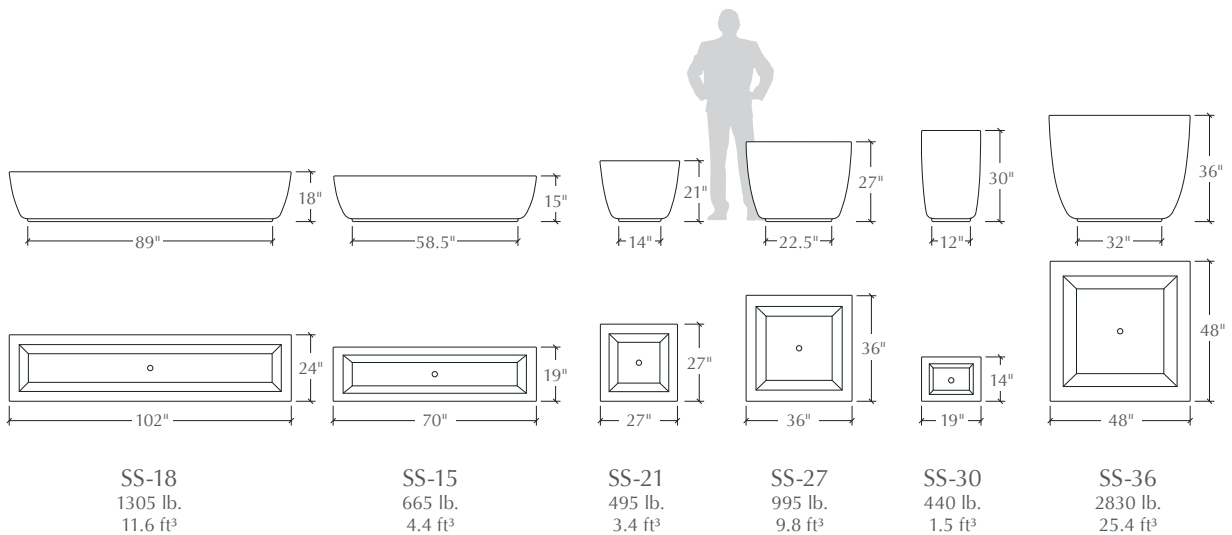

All weights are approximate. Volume is calculated 1" down from the top surface of the planter.

In 2002, Larry Kornegay designed the Square Series exclusively for Kornegay Design® LLC, a Landscape Forms® company

v. 2022.09.13