

# Instructions

Assembly  
Installation  
Operation

7/2007

## Neoliviano Bench

**HANDLE WITH CARE!** Do not place or slide parts on concrete or other hard or abrasive surfaces.

### Recommended procedure for surface mounting:

Each surface mount bench is shipped with two mounting plates installed on every support casting. Each plate can accept one anchor up to 3/8" diameter. Although the anchoring procedure and hardware are the responsibility of the installer, we suggest the following:

1. Select corrosion resistant anchors appropriate for the surface. Your hardware store or builders supply may be able to recommend the proper hardware, tools, and safety equipment.
2. Check the screws that fasten the mounting plates to the bench. Align plates as shown below and tighten mount screws with a 6mm Allen wrench if necessary.
3. Place the bench in the desired position.
4. Mark hole locations.
5. Move the bench to allow access for drilling holes.
6. Install the anchors and bench according to the anchor manufacturer's instructions.

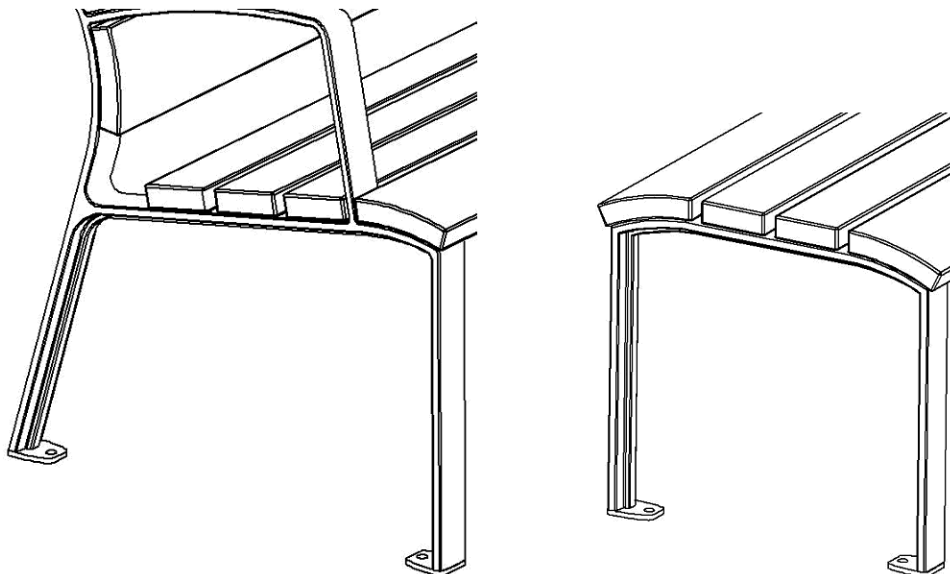

Correct tab alignment for backed and backless benches shown above.

landscapeforms®

Page 1 of 2

431 Lawndale Avenue, Kalamazoo, MI 49048  
PH: 800.521.2546, PH: 269.381.0396, FX: 269.381.3455

# Instructions

Assembly  
Installation  
Operation

## Recommended procedure for embedded mounting:

Each embedded bench is shipped with two M10 threaded rods per support casting. For mounting to existing concrete, we recommend using an adhesive anchoring system (Hilti HIT RE 500 or Powers Fasteners AC100 PLUS™). These products may be used in wet or dry conditions. Gel and cure times vary with temperature. Each bench support requires approximately 1-1/2 ounces of adhesive. Although the anchoring procedure is the responsibility of the installer, we suggest the following:

1. Place bench upside down on non-marring material.
2. Locate and install two M10 threaded rods in each support. Leave 4" of threaded rod sticking out of the support. DO NOT thread rods in until they bottom out.
3. Place the bench in the desired position.
4. Mark hole locations around rods.
5. Move the bench to allow access for drilling holes.
6. Hammer drill 5/8" holes, 4-1/2" deep.
7. Clean holes carefully using a 1" diameter nylon brush and compressed air. For best results use a nozzle that reaches the bottom of the hole. Holes must be free of standing water or ice.
8. Follow the manufacturer's instructions for dispensing adhesive. Fill the holes from the bottom up to avoid air pockets. Fill to a level 1" from the top of each hole. (The adhesive level should rise to the top of the hole as the bench is set in place.)
9. Set the bench in the installed position. Do not disturb the bench during the cure time.
10. Wipe away any spilled adhesive before it gels.